



# ECD485fos User Manual

Industrial Fiber Optics to RS485 (2 or 4-wire)  
Serial Converter (Single Mode)

## 1. Introduction

### 1.1 Block Diagram

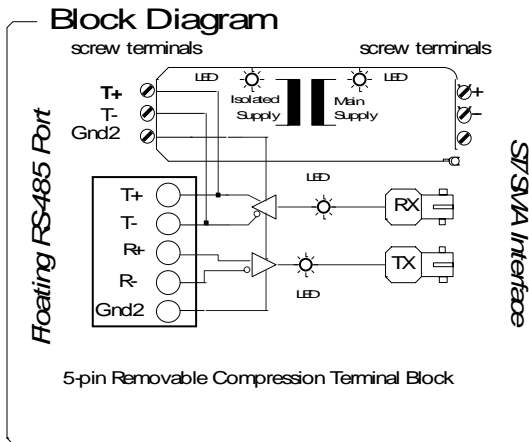

Fig 1. Block diagram

### 1.2 Product Overview

The ECD485fos is designed specifically for using in industrial panel applications. It provides the following unique combination of features:

Fiber optics provides an intrinsically 100% galvanically isolated, noise-free, lightning immune data communications signal. The ECD485fos uses high-quality components to communicate up to 11km at 1310nm over 9/125um single mode fibers. The standard connector is ST but SMA is available upon special request.

The ECD485fos fully supports EIA/RS485 in 2 or 4-wire mode, plus its fully compatible with most EIA/RS422 4-wire links.

The serial port is a removable 5-screw compression terminal for industrial sized field wires.

Optionally, the serial port of the ECD485fos can have 2500v optical/galvanic isolation from the power supply. This is critical with most DC power systems.

For rapid troubleshooting, there are LED indicators for data transmission and power status.

Wide power supply range (9 to 36Vdc) allows use with 9V, 12V, 24V supplies or direct from 12V or 24V battery system. For 110Vac or 230Vac operation, any common 9v or 12Vdc wall transformer can be used.

### 1.3 User Interface

The ECD485fos is designed for user-friendly application. Green LED ps lights when external power is properly applied. Green LED ps/iso lights when the internal isolating DC-DC converter is working properly. This isolation provides over 10,000,000 ohms of resistance between the power supply ground and serial interface ground to eliminate ground loops. Yellow LEDs lights when any data is received on the fiber interface. Yellow LED/Txd lights when any data is received on the serial interface and transmits out at the fiber end.

## Internal Jumper Settings

### 2.1 Selecting 2 or 4-wire operation

The right-most two jumpers (4w & 2w) define 2 or 4-wire operation. For RS485 2-wire, place a shunt/jumper on the 2w position only. For RS485 4-wire or RS422, place a shunt/jumper on the 4w position only. You are not required to externally short T+/R+ and T-/R- for 2-wire operation. By default, we set the operation as 4-wire mode.

### 2.2 Placing your bus terminal resistors

Each RS485 wire pair requires one or two 120 ohm terminal resistors (assuming your cable has a characteristic impedance of 120 ohms). The ECD485fos has two internal 120ohm terminal resistors enabled by the R-Term and T-Term jumpers. For RS485 2-wire bus or point-to-point link, you must enable a terminal resistor at each receive end (total one for each pair, two for 2 pair). For RS485 4-wire bus, you must enable a terminal resistor at each end of each pair (total two for each pair, four for 2 pair). If your cable

has a different impedance - for example, you find quality 100 ohm twisted pair cable easier to buy, you can disable the internal jumpers and install external terminal resistors.

### 2.3 Placing your bus bias resistors

The ECD485fos only works with a proper bias applied to each pair. These bias resistors prevent an idle (floating) wire pair from causing noise, and is critical to proper “auto-line-turnaround”. The ECD485fos has four internal 470 ohm bias resistors. The jumpers RB- & RB+ enable the pull-up/pull-down bias on the receive wire pair R+/R-. The jumpers TT- & TT+ enable the pull-up/pull-down bias on the transmit pair T+/T-. Each wire pair must have at least one, but no more than two sets of bias resistors enabled.

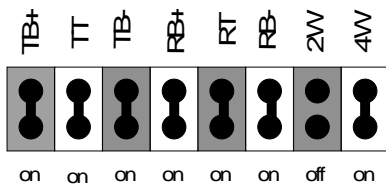

**Fig 2. Jumper Setting (default)**

## 3. Installation

### 3.1 Fiber Optics Connection:

The ECD485fos has either 2 ST-compatible bayonet connectors (option -st) or 2 SMA threaded connectors (option -sma). Note that all fiber optic cables need gentle handling and have a specified minimum bend radius. Please refer to your cable specs for details, but you should plan on providing space to neatly coil a 6 inch or 15cm loop diameter of extra fiber. The ECD485fos’ transmit (Tx) connector is connected to the receive (Rx) connector of the remote device and the ECD485fos’ receiver (Rx) connector is connected to the transmitter (Tx) connector of the remote device.

### 3.2 RS485 & RS422 Wiring (fully isolated, model : ECD485fos-2p)

For galvanically isolated ECD485fos the signal ground (SG) must be connected for RS485 &

RS422. It is also critical that the signal ground be properly connected-you void your warrantee if you do not connect this ground properly. If your RS485 bus does not have the 3<sup>rd</sup> ground wire, then you should at least connect the signal ground (SG) of the RS485 to the nearest device’s digital ground. See ECD application note for more information on the importance of this ground.



**Fig 3. RS485/RS422 4-Wire**

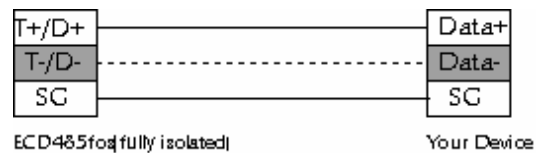

**Fig 4. RS485 2-Wire**

### 3.3 RS485 & RS422 Wiring (non-isolated, model: ECD485fos-1p)

For non-isolated ECD485fos, the signal ground should be left unconnected or (per EIA/RS485) you should insert a 100 ohm 1 watt resistor in series with your signal ground wire. Since in the non-isolated ECD485fos the RS485 signal ground is shorted to your 0V-power supply ground, this resistor discourages damaging ground surges from damaging either the ECD485fos or your attached device. See ECD application note for more information on the importance and possible designs for the ground.

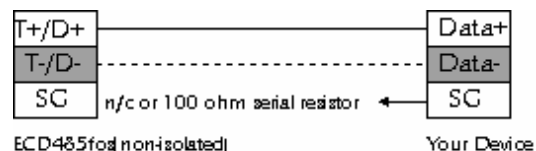

**Fig 5. RS485 2-Wire(non-isolated)**

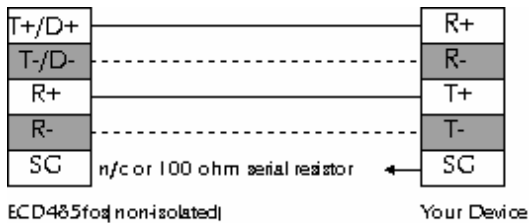

Fig 6. RS485/RS422 4-Wire(non-isolated)

## 4. Application Examples

### 4.1 Standard Point-to-Point Connection

When most industrial people use fiber optics, they use it in a point-to-point connection. The fiber is functioning like a modem or line driver. This example also highlights mixing the ECD232fos to support RS232 at one end and the ECD485fos to support multi-drop RS485 at the other end. Of course, two ECD485fos can also be connected in a point-to-point link. Similarly, a 2-wire at one end can be mixed with a 2-wire at the other end. This goes for the same with both ends set at 4-wire.

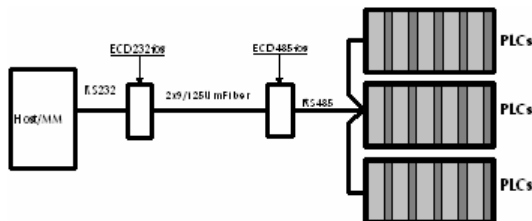

Fig 7. Application example 1

### 4.2 Robust 'Star' Multi-Drop Design

A robust "multi-drop" design uses multiple ECD485fos near the Master in a RS485 multi-drop bus. A master poll is repeated out each of the central ECD485fos units. The master device must also support RS485(2 or 4-wire) or RS422. If your master device has a RS232 port, the RobustDC ECD485IC makes an ideal RS232 to RS485 converter. You'll find using RS485 4-wire with a shared signal reference is the most robust installation. Plus using RS485 4-wire at the master is more efficient since the central ECD485fos will not repeat the slave responses back out to the remote slaves - only the master device sees the slave responses. The ECD485fos

can be configured for RS485 4-wire whether the master device has a RS422 or a RS485 4-wire interface.

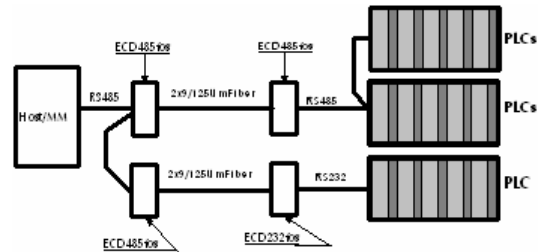

Fig 8. Application example 2

## 5. Technical Specification

### 5.1 Port Description

- 5.1.1 **RS485, RS422:** Working voltage range +12/-7Vdc, Max voltage range +/-15Vdc, Max surge +/-25Vdc.
- 5.1.2 **Fiber Optics:** 1310nm over 9/125um fiber. ST or SMA connectors.
- 5.1.3 **Speed:** Tested to 230K baud, no configuration required.
- 5.1.4 **Character Setting:** any combination of parity, data, stop and start bits; no configuration required.

### 5.2 Isolation (Per ISO/IEC 9549)

- 5.2.1 **Fiber Optics:** Intrinsic full isolation
- 5.2.2 **RS485 to Supply:** model "1p" none; model "2p" 2500V (galvanic, 3Kv test)
- 5.2.3 **Casing:** Dielectric strength per DIN VDE 0303/part 2 is 400KV/cm

### 5.3 Power Supply

- 5.3.1 **ECD485fos-5v:** regulated 5Vdc +/-5%, 1 watt (nominal 200mA)
- 5.3.2 **ECD485fos-dv:** unregulated 9 to 36 Vdc, 1.5watt (nominal 60mA at 24Vdc)

### 5.4 Environmental

- 5.4.1 **Ambient Operating Temp:** -40C to +65C
- 5.4.2 **Ambient Storage Temp:** -40C to +100C
- 5.4.3 **Relative Humidity:** 10-90%, non condensing
- 5.4.4 **Casing:** fungus and termite resistant



5.4.5 **Casing flame characteristics:** self-extinguishing per UL 94V2

## 5.5 Mechanical Dimensions

5.5.1 **Height, Width, Depth** (See drawing)

5.5.2 **Weight:** Approx.: 130g

5.5.3 **Terminal Capacity:** 2.5mm(12AWG)

5.5.4 **Mounting Rail:** DIN EN 50022(35mm sym) DIN EN50025 (32mm sym) Note: removal from a DIN EN50025 rail is difficult.

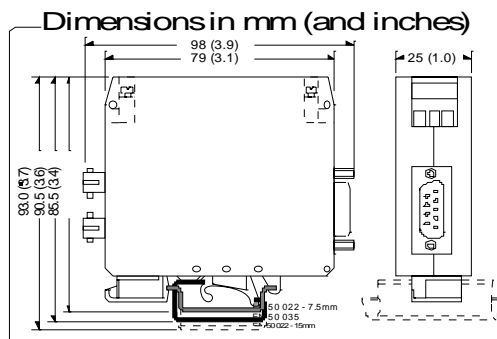

Fig 9 Dimensions